

Operating Instructions

Original Operating Instructions

Mline®

Mechanical Pipette

Single-channel Models | Multi-channel Models



1000134955



SARTORIUS

Contents

1	About These Instructions	5
1.1	Validity.....	5
1.2	Related Documents.....	5
1.3	Target Groups.....	6
1.4	Symbols Used.....	6
1.4.1	Warnings in Operation Descriptions.....	6
1.4.2	Other Symbols Used.....	6
2	Safety Instructions	7
2.1	Intended Use.....	7
2.1.1	Modifications to the Device.....	7
2.1.2	Repairs to the Device.....	7
2.2	Qualifications of Personnel.....	8
2.3	Functionality of the Device Parts.....	8
2.4	Risk of Injury During Prolonged Pipetting.....	8
3	Device Description	9
3.1	Device Overview.....	9
3.2	Pipette Tips.....	10
3.2.1	Safetyspace® Filter Tips.....	10
3.3	Adjustment Tool.....	11
3.4	Pipetting Practice.....	11
3.5	Initial Adjustment and Follow-up Adjustment.....	11
4	Installation	12
4.1	Scope of Delivery.....	12
4.2	Unpacking.....	12
4.3	Tagging the Pipette.....	12
4.4	Storing the Pipette When Not in Use.....	13
5	Commissioning	14
5.1	Adjusting the Volume.....	14
5.2	Attaching the Tip.....	14
5.3	Ejecting the Tip.....	15
5.4	Inserting or Ejecting a Safe-Cone Filter.....	15
5.4.1	Inserting a Safe-Cone Filter.....	16
5.4.2	Ejecting the Safe-Cone Filter.....	16
6	Operation	17
6.1	Considering Good Pipetting Practices.....	17
6.2	Forward Pipetting.....	18
6.3	Reverse Pipetting.....	18
6.3.1	Repetitive Reverse Pipetting.....	19
7	Cleaning and Maintenance	20
7.1	Testing Chemical Resistance.....	20
7.2	Cleaning the Outer Surface of the Pipette.....	20
7.3	Maintenance Schedule.....	21

7.4	Cleaning and Inspecting the Pipette.....	22
7.4.1	Disassembling the Lower Part of the Pipette (Single-channel Pipettes).....	22
7.4.2	Cleaning and Greasing the Lower Part of the Pipette (Single-channel Pipettes).....	24
7.4.3	Assembling the Lower Part of the Pipette (Single-channel Pipettes).....	25
7.5	Sterilizing the Pipette.....	26
7.5.1	Autoclaving the Pipette.....	26
7.5.2	Sterilizing the Pipette Using UV Radiation.....	26
7.6	Defining the Test Routine for the Routine Test.....	27
7.7	Performing the Routine Test.....	28
7.7.1	Aspirating the Test Water.....	28
7.7.2	Dispensing Test Water and Performing the Measurement.....	29
7.7.3	Evaluating Measured Values.....	29
7.8	Adjusting the Pipette.....	30
8	Malfunctions.....	31
9	Storage and Shipping.....	32
9.1	Storing.....	32
9.2	Returning the Device and Parts.....	32
10	Disposal.....	33
10.1	Disposing of the Device and Parts.....	33
11	Technical Data.....	34
11.1	Dimensions and Weights.....	34
11.1.1	Single-channel model.....	34
11.1.2	Multichannel model.....	34
11.2	Ambient Conditions at the Installation Site.....	35
11.3	Materials.....	36
11.3.1	Upper Part and Lower Part of Housing.....	36
11.3.2	Model-Dependant Materials of Lower Part of Housing (lower part) and Tip Ejector Components.....	37
11.4	Cleaning Procedure and Cleaning Agent.....	38
11.5	Adjustment.....	39
11.5.1	Initial Adjustment.....	39
11.6	Routine test.....	39
11.6.1	Conditions for Aspirating the Test Liquid.....	39
11.6.2	Correction Factor Z ($\mu\text{L}/\text{mg}$) for Routine Test.....	39
11.7	Performance Specifications.....	40
11.7.1	Single-Channel Models.....	40
11.7.2	Multichannel Models.....	42
11.8	Conformity.....	42
12	Accessories and Consumables.....	43
12.1	Accessories.....	43
12.2	Consumables.....	43
13	Sartorius Service.....	44

1 About These Instructions

1.1 Validity

These instructions are part of the device; they must be read in full and kept in a safe place. These instructions apply to the device in the following versions:

Device	Volume Range (μl)	Maximum Volume / Nominal Volume (μl)	Item number
Mline® Mechanical Pipette			
Single-channel	0.3 - 3	3	725010
	1 - 10	10	725020
	2 - 20	20	725030
	10 - 100	100	725050
	20 - 200	200	725060
	100 - 1000	1000	728070
	500 - 5000	5000	725080
	1000 - 10,000	10000	725090
8-channel	1 - 10	10	725120
	10 - 100	100	725130
	30 - 300	300	725140
12-channel	1 - 10	10	725220
	10 - 100	100	725230
	30 - 300	300	725240

1.2 Related Documents

- In addition to these instructions, observe the following documents: Instructions for consumables, accessories, e.g., pipette holder, pipette tips

1.3 Target Groups

These instructions are addressed to the following target groups. The target groups must possess the specified knowledge.

Target Group	Knowledge and Qualifications
Operator	The operator is familiar with the device and the associated work processes. The operator understands the hazards which may arise when working with the device and knows how to prevent them.

1.4 Symbols Used

1.4.1 Warnings in Operation Descriptions

NOTICE

Denotes a hazard that may result in property damage if it is **not** avoided.

1.4.2 Other Symbols Used

- ▶ Required action: Describes activities that must be carried out. The activities in the sequence must be carried out in succession.
- ▷ Result: Describes the result of the activities carried out.

2 Safety Instructions

2.1 Intended Use

The Mline® pipette is a universal laboratory device. The pipette is an air-cushion piston pipette and is intended for dispensing liquids in a variety of applications.

The device's volume range must be taken into consideration when selecting the application (see Chapter "11.7 Performance Specifications", page 40). Volume deviations can be caused by dosing liquids with different physical properties.

Pipette tips suitable for the device must be used (see Chapter "12.2 Consumables", page 43). Using suitable tips guarantees the pipette's performance specifications and ensures pipetting accuracy and precision.

The tips are designed for single use and need to be disposed of after the single use.

The pipette is suitable for left- and right-handed users.

The device is intended solely for use in accordance with these instructions. Any other use is considered **improper**.

Operating Conditions for the Device

Do **not** use the device in potentially explosive environments. Only use the device indoors.

The device may only be used with the equipment and under the operating conditions described in the Technical Data section of these instructions.

2.1.1 Modifications to the Device

If the device is modified: Persons may be put at risk. Device-specific documents and product approvals may lose their validity.

Contact Sartorius if you have any questions concerning modifications.

2.1.2 Repairs to the Device

Device repairs may only be carried out by persons with specialized knowledge of the device. If the device is **not** repaired by a specialist: Persons may be put at risk. Device-specific documents and product approvals may lose their validity.

Sartorius recommends that any repair work, even that carried out after the end of the warranty period, is carried out by Sartorius Service or after consulting with Sartorius Service.

2.2 Qualifications of Personnel

Persons who do not possess adequate knowledge about how to use the device may injure themselves and other persons.

If a particular qualification is required for an activity: The target group is specified. If **no** qualification is specified: The activity can be performed by the "Operator" target group.

2.3 Functionality of the Device Parts

Non-functioning device parts, e.g., as a result of damage or wear, can cause malfunctions. There is a risk of injury to persons.

- ▶ If device parts are **not** functioning: Do **not** use the device.

2.4 Risk of Injury During Prolonged Pipetting

Prolonged pipetting can cause Work Related Upper Limb Disorder (WRULD) and Repetitive Strain Injury (RSI).

- ▶ Take regular breaks during pipetting and in doing so relax the hand.
- ▶ Stand or sit upright during pipetting.
- ▶ Place the index finger under the finger support and operate the device with the thumb.
- ▶ Do **not** cramp during pipetting.

3 Device Description

3.1 Device Overview

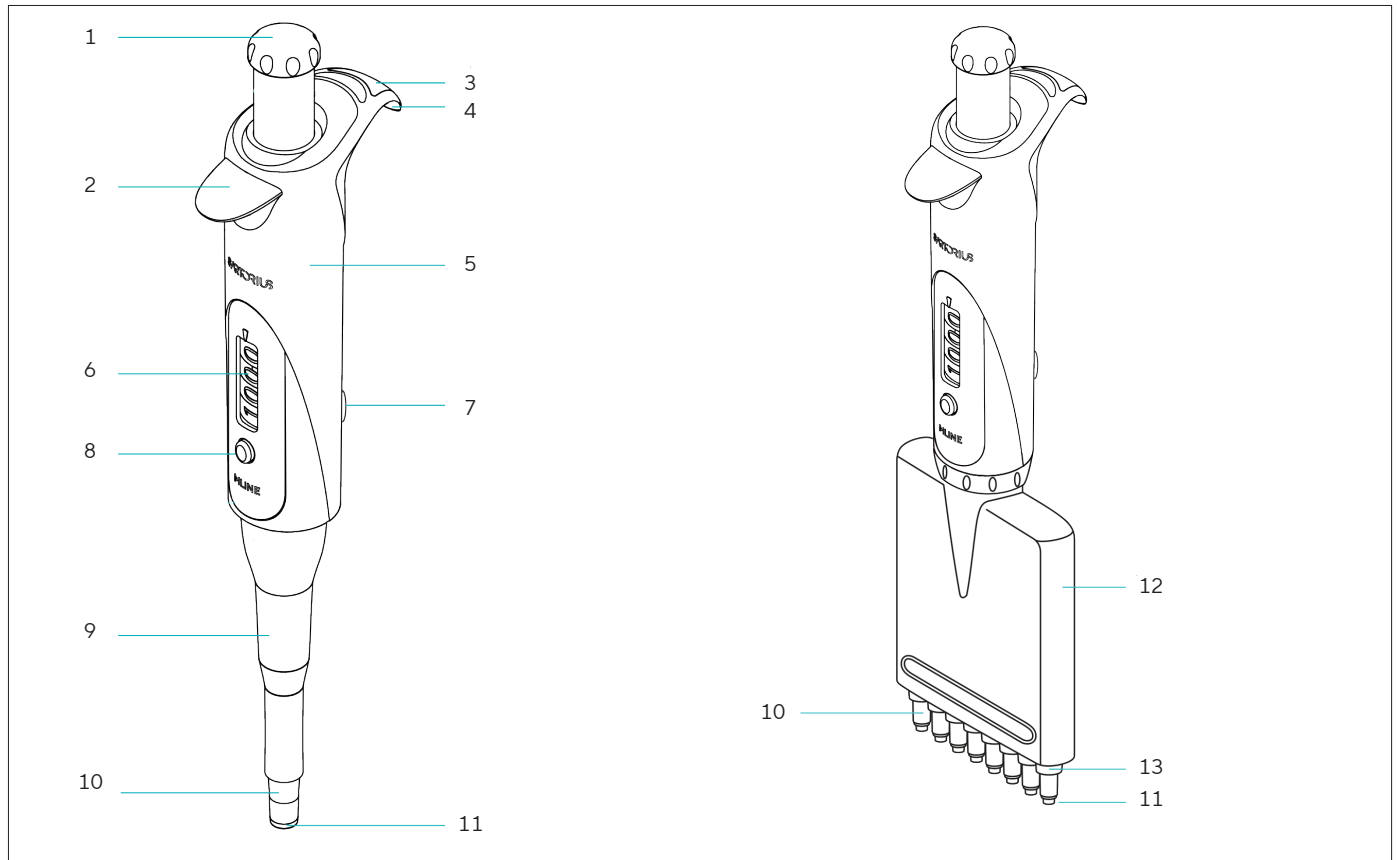

Fig. 1: Single-channel and multichannel models (example)

Pos.	Name
1	Operating button
2	Tip ejector button
3	ID window and label
4	Finger support
5	Handle
6	Display
7	Calibration screw
8	Volume lock button
9	Tip ejector collar
10	Tip cone
11	Safe-Cone Filter
12	Tip cone housing
13	Tip ejector bar

3.2 Pipette Tips

Sartorius tips are made of pure virgin polypropylene and manufactured in protected cleanroom conditions.

Sartorius non-filter tips are available in trays, bulk packages, and space-saving refill systems. Both non-filter tips and trays are autoclavable at 121°C (252°F), 20 min, 1 bar (15 psi). All Single Tray racks and clean Refill Packs are certified RNase, DNase, and endotoxin-free.

3.2.1 Safetyspace® Filter Tips

To avoid aerosol contamination, use Safetyspace® filter tips and discard them after each pipetting. These can also be used to avoid sample loss caused by the sample coming into contact with the filter. The extra air gap between the sample and the filter ensures that even foaming or viscous liquids do not come into contact with the filter in reverse pipetting or repetitive/multiple dispensing modes.

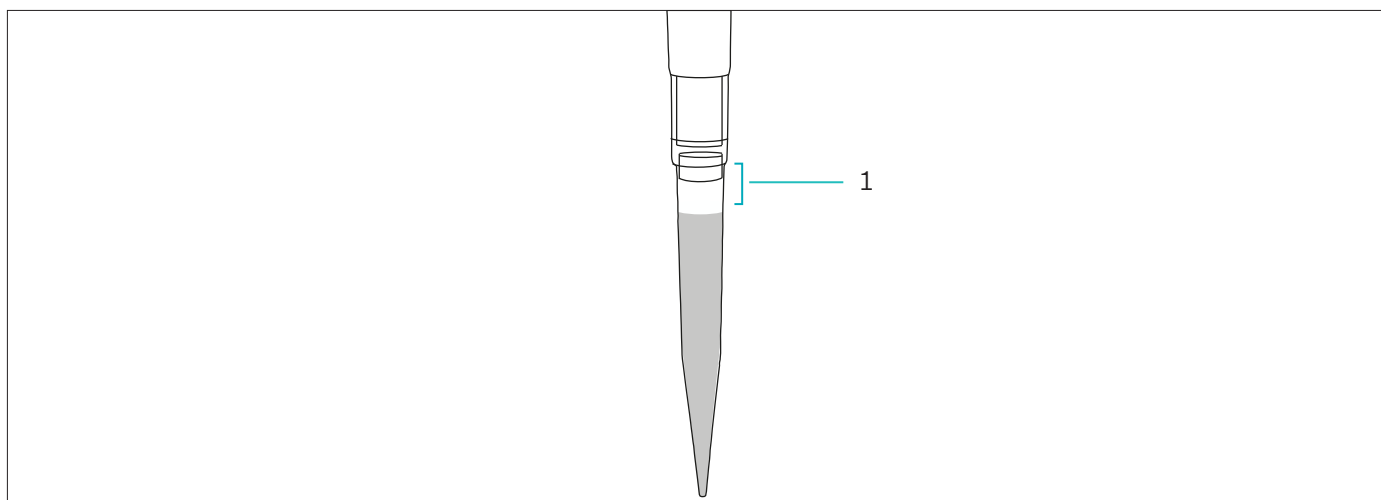

Fig. 2: Safetyspace® filter tip

Pos.	Name
1	Safetyspace® air gap

3.3 Adjustment Tool

The adjustment tool is required to adjust the pipette and perform assembly work on the pipette.

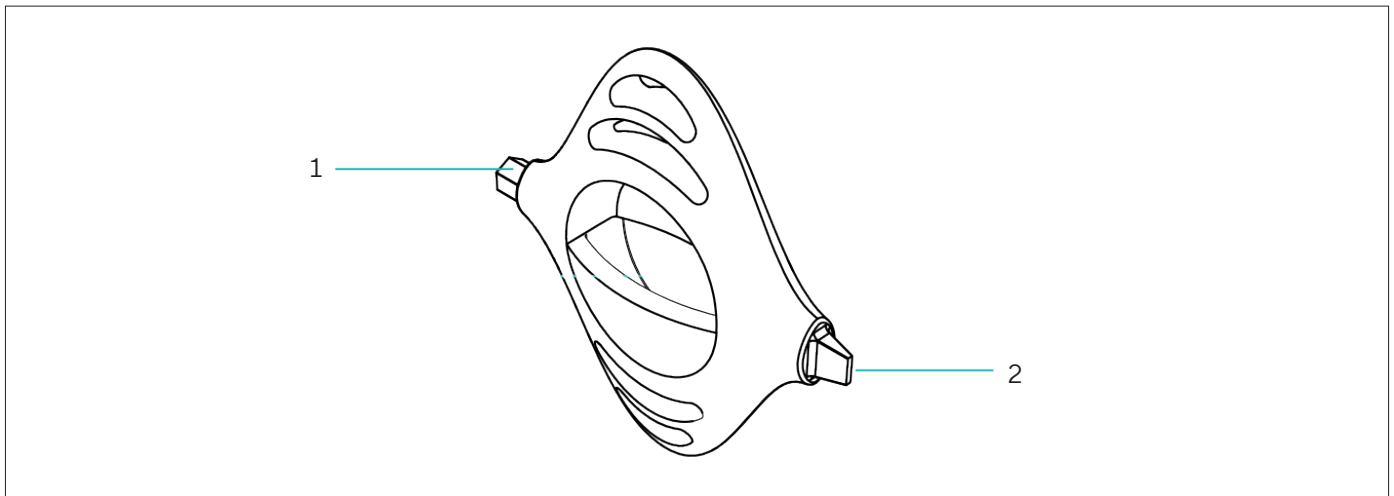

Fig. 3: Adjustment tool

Pos.	Name
1	For calibration
2	For opening the cover of the calibration screw

3.4 Pipetting Practice

The Mline® pipette is used for forward and reverse pipetting.

3.5 Initial Adjustment and Follow-up Adjustment

Initial adjustment: The pipette is adjusted on delivery in accordance with ISO 8655-1 (see Chapter “11.5 Adjustment”, page 39).

Follow-up adjustment: The pipette can be re-adjusted, e.g., if it is determined that the delivered volume is **not** within the error limits or a liquid other than water is to be pipetted. The described procedure must be used for the adjustment.

The current pipette adjustment is displayed in the settings window for adjustment.

4 Installation

4.1 Scope of Delivery

Item	Quantity
Mline® Mechanical Pipette	1
Identification tag	4
Adjustment tool	1
Safe-Cone Filter (not for 3 µl 10 µl models)	12
Quality Control Certificate	1
Quick Start Guide	1

4.2 Unpacking

Procedure

- ▶ Unpack the device.
- ▶ Sartorius recommends keeping the original packaging to return the device appropriately, e.g., for repairs.

4.3 Tagging the Pipette

Each pipette can be identified with a tag on the finger support. Use personalized tags to make each pipette easily identifiable.

If the pipette needs to be autoclaved, ensure that suitably resistant ink is used.

Procedure

- ▶ Remove the ID window (1) using the adjustment tool.
- ▶ Remove the tag and mark the identifying information on it.
- ▶ Position the tag in place and clip the ID window back into place.

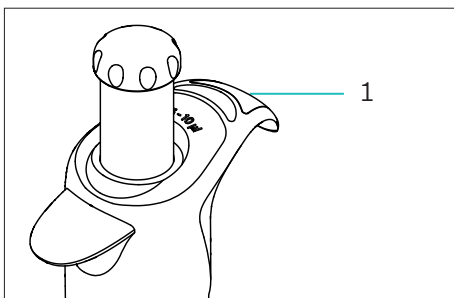

4.4 Storing the Pipette When Not in Use

For convenience and safety, always keep the pipette upright. A pipette holder or a pipette stand can be used for this purpose.

The pipette holder must be affixed to a suitable surface.

Procedure

- ▶ Clean the shelf surface with ethanol.
- ▶ Remove the protective paper from the adhesive tape.
- ▶ Install the holder by pressing it against the edge of the shelf and hold for 30 seconds.
- ▶ Allow a waiting time of 20 minutes. This allows the adhesive tape and surface to bond.
- ▶ Hook the finger support onto the holder.

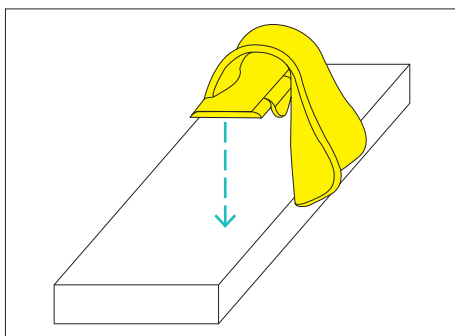

5 Commissioning

5.1 Adjusting the Volume

The volume to be aspirated (pipetting volume) is shown on the display. To adjust the volume, hold down the volume lock and rotate the operating button.

NOTICE

Damage to the setting mechanism!

The setting mechanism can become damaged if turned too far.

- ▶ Ensure that you do not turn the volume setting beyond the specified range.

Procedure

- ▶ Press and hold the volume lock button (2)
- ▶ Turn the operating button (1) to adjust the volume. Do not turn the volume setting beyond the specified range.
- ▶ Release the volume lock button.

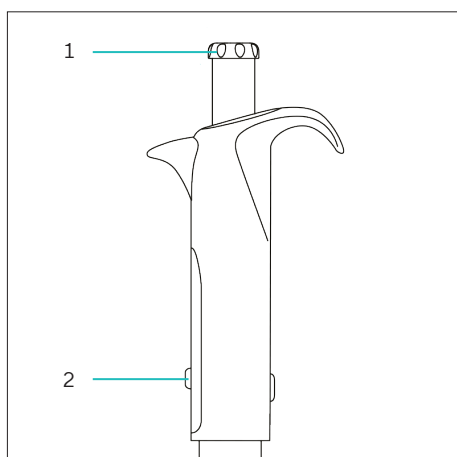

5.2 Attaching the Tip

Sartorius recommends using suitable pipette tips for maximum accuracy and precision (see Chapter „12.2 Consumables“, page 43). The Optiload spring-loaded tip cone of the pipette ensures optimal sealing.

The pipette is fitted with a spring-loaded tip cone to ensure optimal sealing.

Procedure

- ▶ Make sure the pipette tip cone(s) are clean and undamaged.
- ▶ Press the tip cone(s) carefully into a tip held in a tip tray.
- ▶ **Do not** force the pipette into the tip, or rock it from side to side, or front to back when attaching tips.
- ▶ Both sealing surfaces must be clean. The tip is fitted securely when the sealing ring is visible between the sealing surfaces.

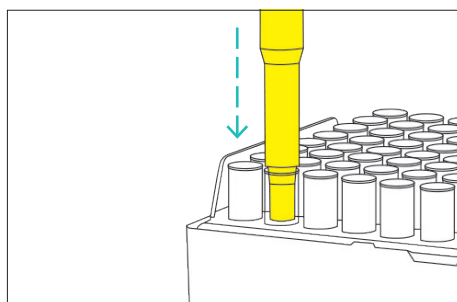

5.3 Ejecting the Tip

The pipette has a tip ejector, which reduces the risk of contamination.

Procedure

- ▶ Hold pipette over a suitable waste vessel.
- ▶ Press the tip ejector button with your thumb.

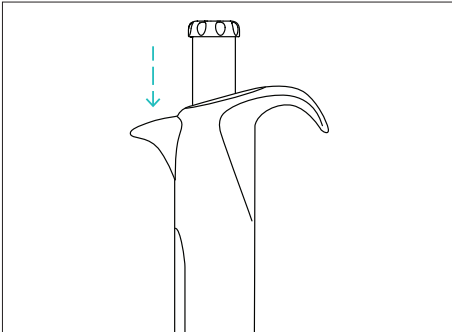

5.4 Inserting or Ejecting a Safe-Cone Filter

Replaceable Sartorius Safe-Cone Filters can be used with your pipette to help prevent liquids and aerosols from entering the pipette housing, and causing contamination or damage.

We recommend to use Safe-Cone filters when using non-filter tips (not for 3 μ l | 10 μ l models). The operating button allows safe and easy filter ejection. Do **not** use a Safe-Cone filter with a filter tip.

Safe-Cone Filters are available in Standard or Plus versions. The Standard filter is recommended for general applications, the Plus filter for more demanding applications, such as:

- Cell culture
- Bacterial and virological work
- Molecular biology

The Safe-Cone filter must be changed regularly. The change interval depends on the application, but regular daily replacement is recommended and always in the case of over-aspiration. If the pipette is **not** functioning properly, change the filter.

5.4.1 Inserting a Safe-Cone Filter

Procedure

- ▶ Clean the tip cone if necessary.
- ▶ Insert a new filter.

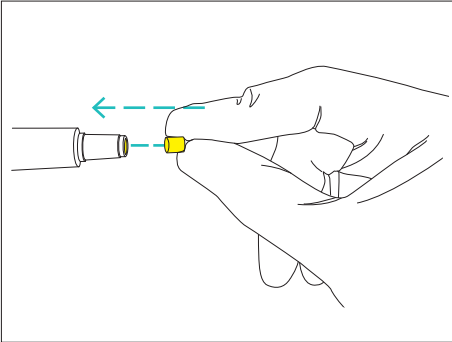

5.4.2 Ejecting the Safe-Cone Filter

The Safe-Cone Filter can be removed contact-free using the operating button.

Procedure

- ▶ Hold pipette over a suitable waste vessel.
- ▶ Remove the cap.
- ▶ Press the operating button.
- ▶ Replace the cap.

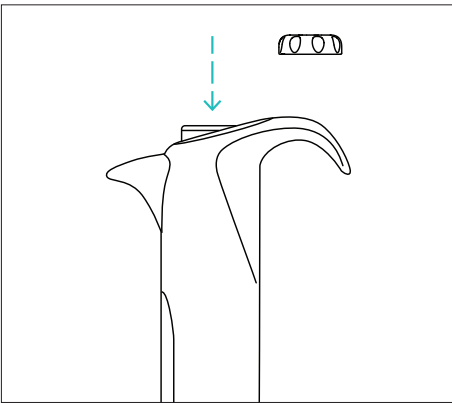

6 Operation

6.1 Considering Good Pipetting Practices

- Make sure the tip is firmly attached to the tip cone(s).
- Pre-rinse the tip before aspirating by filling and emptying the tip three to five times. This is particularly important when pipetting liquids with a viscosity and density greater than water, or volatile liquids with high vapor pressure (such as ethanol).
- Make sure the pipette, tip, and liquid are at the same temperature (if possible).
- Hold the pipette upright when aspirating, and only place the tip a few millimeters into the liquid (recommended immersion depth see Chapter “11.6.1 Conditions for Aspirating the Test Liquid”, page 39).
- Always press and release the operating button slowly and smoothly.
- When pipetting a liquid that is **not** at the ambient temperature, the tip must be changed after each pipetting. Do **not** rinse the tip before use.
- To avoid contaminating the pipette’s housing with either the sample in the tip or the work surface, do **not** lay the pipette on its side.
- Never strike the tip cone against the tip tray.
- When handling infectious or radioactive agents, wear appropriate protective gear and take all sensible precautions.
- Avoid exposing the unit to extreme temperature changes, humidity, or dust. Observe the operating conditions (see Chapter “11.2 Ambient Conditions at the Installation Site”, page 35).

6.2 Forward Pipetting

Forward pipetting is the most common pipetting technique. It uses a blow-out function to ensure complete delivery of the liquid. This technique aspirates and then dispenses the selected liquid volume. It is recommended for aqueous liquids, liquids containing small amounts of detergents or proteins, and solvents.

Procedure

- ▶ Fit the tip onto the pipette tip cone.
- ▶ Press the operating button to the first stop.
- ▶ Place the tip just under the surface of the liquid and smoothly release the operating button, allowing it to return to the starting position. Wait one second.
- ▶ Carefully withdraw the tip from the liquid, touching it against the edge of the container to remove any excess liquid.
- ▶ Dispense the liquid by pressing the operating button to the first stop (1).
- ▶ After a short pause, press the operating button to the second stop (2). This empties the tip.

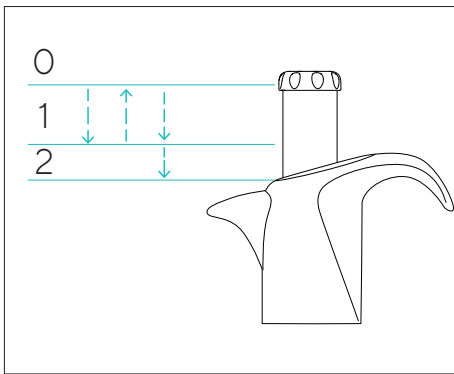

6.3 Reverse Pipetting

Reverse pipetting is recommended for highly viscous, biological, or foaming liquids, or very small volumes. The selected volume is aspirated into the tip along with an excess volume.

Delivery is done without blow-out ensuring the excess volume remains in the tip. This excess is then discarded after the selected volume is aspirated. You may need to adjust the pipette in order to use the reverse pipetting technique.

Procedure

- ▶ Fit the tip onto the pipette tip cone.
- ▶ Press the operating button all the way to the second stop.
- ▶ Place the tip just under the surface of the liquid and smoothly release the operating button, allowing it to return to the starting position.
- ▶ Carefully withdraw the tip from the liquid, touching it against the edge of the container to remove any excess from the tip.

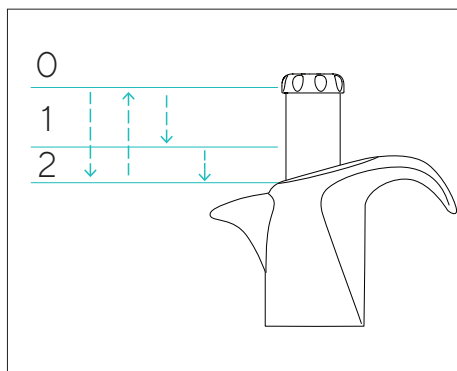

- ▶ Press the operating button smoothly to the first stop (1) to deliver the preferred volume. The liquid that remains in the tip may **not** be included in the delivery.
- ▶ Discard the remaining liquid by pressing the operating button to the second stop (2).

6.3.1 Repetitive Reverse Pipetting

The reverse technique allows you to repeatedly deliver the same volume.

Procedure

- ▶ Fit the tip onto the pipette tip cone.
- ▶ Press the operating button all the way to the second stop.
- ▶ Repeat the following steps as many times as necessary:
 - ▶ Place the tip just under the surface of the liquid and smoothly release the operating button, allowing it to return to the starting position.
 - ▶ Carefully withdraw the tip from the liquid, touching it against the edge of the container to remove any excess from the tip.
 - ▶ Press the operating button smoothly to the first stop (1) to deliver the preferred volume. The liquid that remains in the tip may **not** be included in the delivery.
- ▶ When finished dispensing: Discard the remaining liquid by pressing the operating button to the second stop (2).

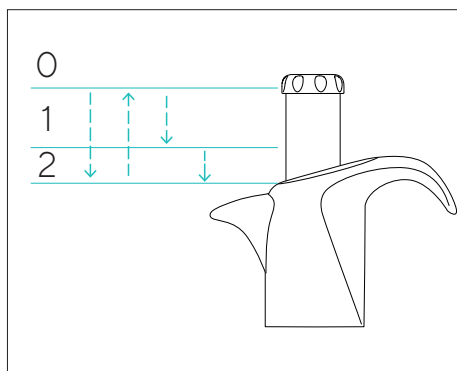

7 Cleaning and Maintenance

7.1 Testing Chemical Resistance

Information on interactions of pipette materials with organic and inorganic solutions, solvents and corrosive chemicals can be provided on request.

Procedure

- ▶ Check that the pipette materials are chemically compatible with the detergent, disinfectant, or decontaminant liquids to be used (pipette materials see Chapter “11.3 Materials”, page 36).

7.2 Cleaning the Outer Surface of the Pipette

We recommend to clean the surface of the device daily. To clean and decontaminate the outer surface of the pipette, use a disinfectant liquid or mild detergent and a soft, lint-free cloth.

The cleaning agent and decontamination agent must be suitable for the device materials (see Chapter “11.3 Materials”, page 36 and Chapter “11.4 Cleaning Procedure and Cleaning Agent”, page 38).

We recommend using gloves when cleaning the pipette.

Procedure

- ▶ Daily check the Mline® pipette to ensure it is clean.
- ▶ Gently clean the surface of the pipette with the moistened cloth and wipe it dry. Pay special attention to the tip cone.
- ▶ Replace the Safe-Cone filter.

7.3 Maintenance Schedule

Interval	Component	Activity	Chapter, page
Regularly, depending on the operating conditions	Safe-Cone Filter	Replace the Safe-Cone Filters.	5.4, 15
	Single-channel models: Lower part of the device	Clean the lower parts and grease components.	7.4, 22
	Multi-channel models: Lower part of the device	For cleaning and greasing the lower parts contact Sartorius Service.	
	Device	Sterilise the device.	7.5, 26
Regularly, e.g., every 3 months and after each in-house maintenance	Device	Perform a routine test to check the pipette performance.	7.7, 28
6 to 24 months, depending on the operating conditions	Device	Contact Sartorius Service for calibrating the device.	

7.4 Cleaning and Inspecting the Pipette

7.4.1 Disassembling the Lower Part of the Pipette (Single-channel Pipettes)

The following information only applies to single-channel pipettes. For cleaning multi-channel pipettes contact Sartorius Service.

Pipette Models (Single-channel Models)

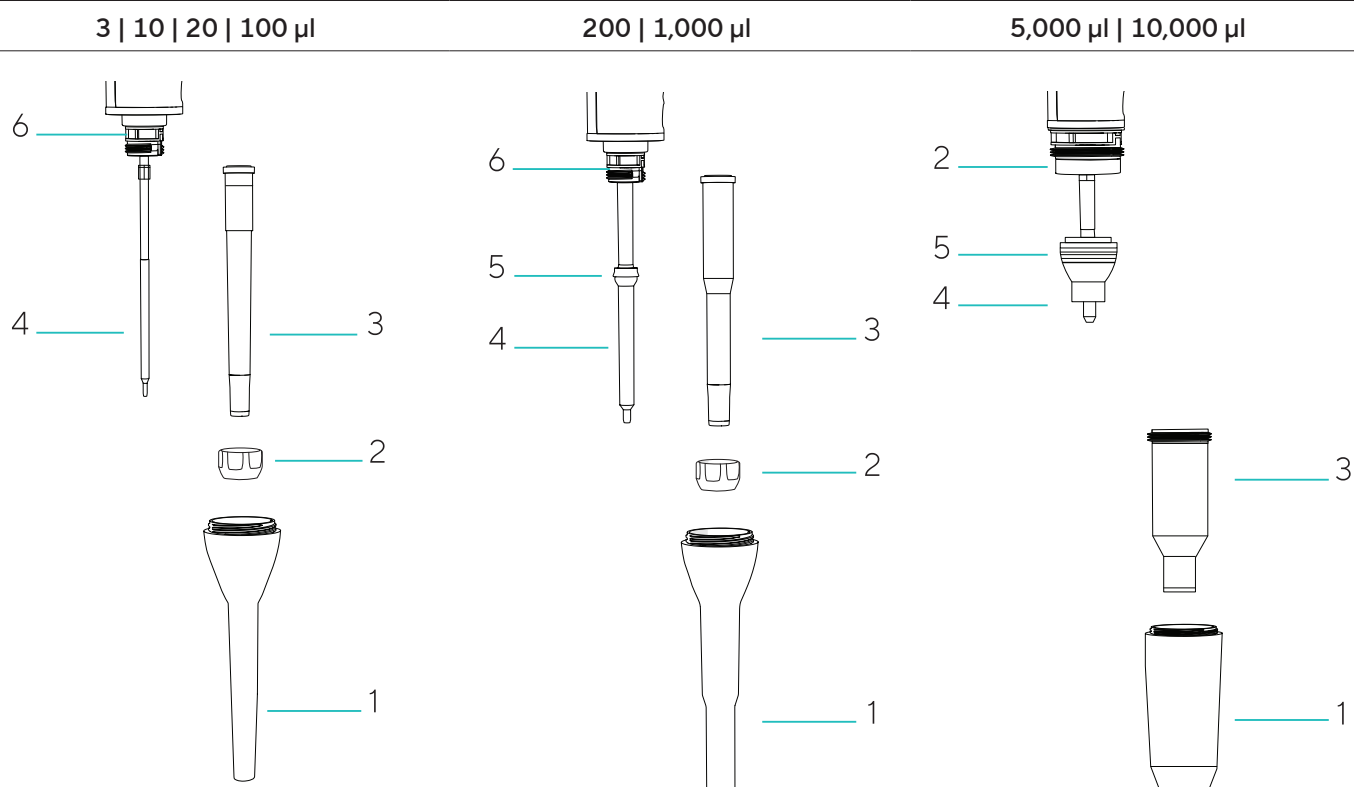
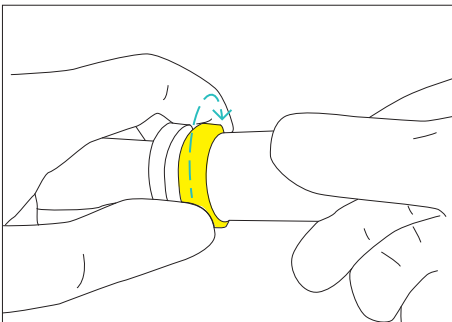
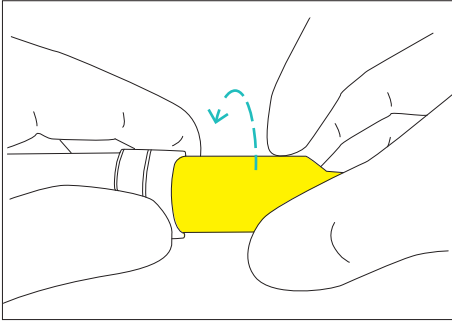

Fig. 4: Lower parts of pipette models

Pos.	Name
1	Tip ejector collar
2	Locking ring
3	Tip cone cylinder
4	Piston
5	Piston seal
6	Tip cone holder

Procedure

- ▶ If available: Eject the tip cone filter (see Chapter “5.4 Inserting or Ejecting a Safe-Cone Filter”, page 15).
- ▶ Unscrew the tip ejector collar counterclockwise and remove it.
- ▶ Depending on the pipette volume disassemble the lower parts of the pipette as follows:
 - ▶ Models with volumes of 3 μl to 1000 μl : Loosen the tip cone holder by turning counterclockwise and carefully remove it with the tip cone.
 - ▶ Models with volumes of 5000 μl : Hold the tip cone holder firmly with the fingers of one hand and then turn the tip cone cylinder counterclockwise with the other hand. When doing so, do not turn the tip cone holder and the tip cone cylinder at the same time as this will break the pipette.



- ▶ Models with volumes of 10,000 μl : Hold the tip cone cylinder firmly and turn the tip cone holder clockwise. When doing so, do not turn the tip cone cylinder as this will break the pipette.

7.4.2 Cleaning and Greasing the Lower Part of the Pipette (Single-channel Pipettes)

Avoid excess grease, too much grease can block the piston. Only use grease that is recommended by Sartorius.

The following information only applies to single-channel pipettes. For cleaning multi-channel pipettes contact Sartorius Service.

Procedure

- ▶ Clean the tip ejector collar, the tip cone holder and locking ring, the tip cone cylinder, and the piston with a disinfectant liquid or mild detergent and a soft, lint-free cloth.
- ▶ Clean the inside of the tip ejector and the tip cone cylinder with a cotton swab. Be careful with 3, 10, 20, and 100 μl pipettes to ensure that the seal inside the tip cone is not damaged.
- ▶ Rinse the parts with distilled water if necessary and allow them to dry.
- ▶ Depending on the pipette volume grease the lower parts as follows:
 - ▶ For 3 μl , 10 μl , 20 μl and 100 μl volume models: Apply a thin layer of grease on the piston (1).

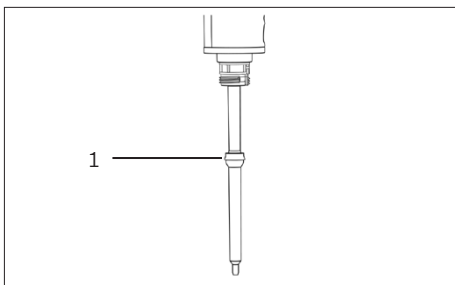
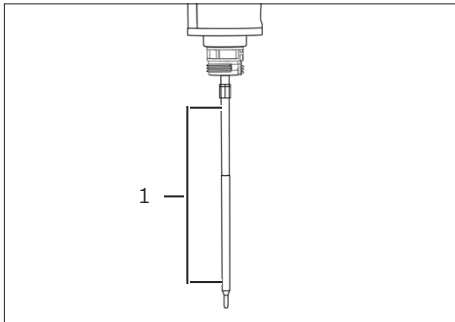

- ▶ For 200 μl or 1,000 μl volume models: Apply a thin layer of grease around the piston seal (1).

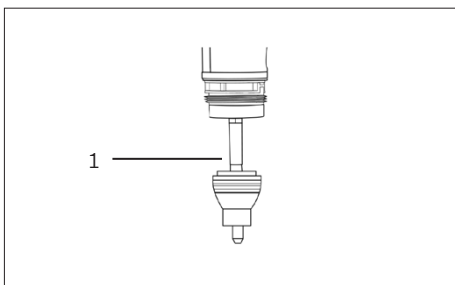

- ▶ For 5,000 μl or 10,000 μl volume models: Apply a thin layer of grease on the interior of the tip cone cylinder and around the piston seal (1).

7.4.3 Assembling the Lower Part of the Pipette (Single-channel Pipettes)

Before reassembling, check that there is **no** lint or other particles on the surface of the piston.

The following information only applies to single-channel pipettes. For cleaning multi-channel pipettes contact Sartorius Service.

Procedure

- ▶ Depending on the pipette volume reassemble the lower parts as follows:
 - ▶ For 3 μ l to 1,000 μ l volume models: Carefully place the tip cone cylinder on the piston and attach it by screwing the locking ring clockwise.
 - ▶ For 5,000 μ l volume models: Carefully place the tip cone cylinder on the piston and screw clockwise. Make sure the tip cone cylinder is properly tightened. **Avoid** over-tightening.

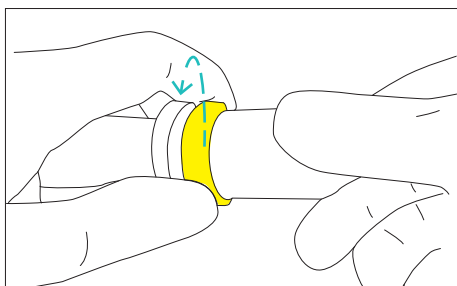
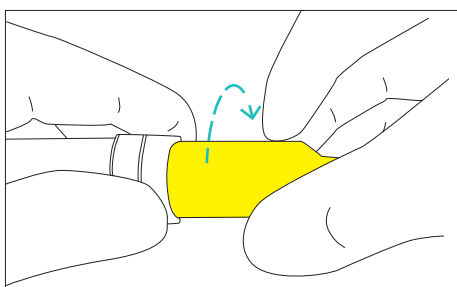

- ▶ For 10000 μ l volume models: Carefully place the tip cone cylinder on the piston and screw the locking ring counterclockwise. Make sure the tip cone cylinder is properly tightened. **Avoid** over-tightening.
- ▶ Attach the tip ejector collar by screwing it clockwise.
- ▶ Insert a new tip cone filter.
- ▶ Press the operating button several times to ensure that the grease has spread evenly.
- ▶ Perform a routine test for the pipette.

7.5 Sterilizing the Pipette

The Mline® pipette can be sterilized using autoclaving, UV radiation, disinfectant, or decontaminant liquids. Always follow the instructions below.

7.5.1 Autoclaving the Pipette

Procedure

- ▶ If available: Eject the tip cone filter (see Chapter “5.4 Inserting or Ejecting a Safe-Cone Filter”, page 15).
- ▶ Multichannel models: Hold the connecting piece and unscrew the bottom part by turning counterclockwise.

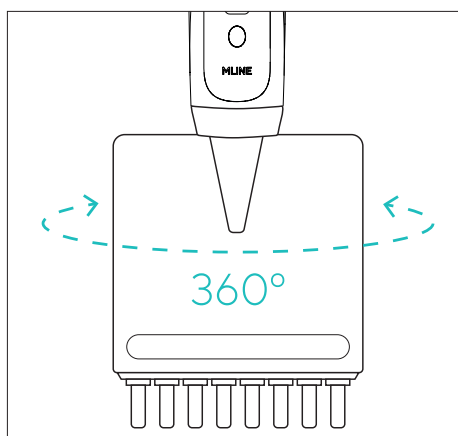

- ▶ Put the pipette into the sterilization bag, and place the bag into the autoclave. Observe the limits for autoclaving (see Chapter “11.4 Cleaning Procedure and Cleaning Agent”, page 38).
- ▶ Let the parts cool and dry overnight.
- ▶ Perform one of the following steps depending on the pipette model:
 - ▶ Multichannel models: Hold the connecting piece and screw on the bottom part by turning clockwise.
 - ▶ Single-channel models: Check if the bottom parts have loosened during autoclaving and re-tighten if necessary.
- ▶ We recommend checking the function of the pipette after each time it is autoclaved.
- ▶ If required: We recommend lubricating the piston seal after every tenth autoclaving procedure (see Chapter 7.4.3, page 25).

7.5.2 Sterilizing the Pipette Using UV Radiation

Mline® pipettes are made of UV-resistant materials and tolerate temporary exposure to UV radiation. Take note that prolonged or frequent exposure to UV radiation may cause yellowing and brittling of the pipette.

7.6 Defining the Test Routine for the Routine Test

We recommend testing the performance of the pipette regularly in a routine test (for intervals, see Chapter “7.3 Maintenance Schedule”, page 21).

We recommend defining a test routine for the routine test that takes into account the following criteria:

Test Routine	Criteria	Explanation
General test routine	Accuracy requirements of the relevant application	
	Frequency of use	
	Number of operators for the device	
	Nature of the liquid dispensed	
	Maximum permitted error limits for systematic and random errors, as per ISO 8655-2	As per ISO 8655-2
	Acceptable error range taking into account: <ul style="list-style-type: none"> – Application – Application area – Conditions for precision of the application 	Sartorius specifications were achieved in strictly controlled conditions, as per ISO 8655-6 (see Chapter “11.7 Performance Specifications”, page 40).
	Multistage routine test with three volumes recommended: <ul style="list-style-type: none"> – 100% of the nominal volume – 50% of the nominal volume – 10% of the nominal volume 	
Risk of the application, e.g. in relation to accuracy		
Additional requirements for multi-channel pipettes	All channels of the multi-channel pipette must be tested individually. The following options are available for doing this:	
	Use a multi-channel balance that measures the dispensed liquid from all channels in parallel.	The test liquid is aspirated, dispensed and measured in all channels at the same time.
	Use a single-channel balance that measures the dispensed test liquid from one channel.	The test liquid for each channel is aspirated, dispensed and measured individually in succession. The test liquid from the other channels is discarded as residual water.

Procedure

- ▶ Prepare a test routine that takes into account the required criteria for the routine test on the device.

7.7 Performing the Routine Test

A routine test with an analytical balance (single-channel balance) is described below. Further information on the possible test routines is described in the ISO 8655 series of standards, e.g., for the testing of multi dispensing in pipetting mode.

- Materials:
- Test liquid (test water): distilled, deionized water (ISO 3696, quality 3)
 - Test water container
 - Measuring container, for positioning on the analytical balance
 - Pipette tips
- Tool: Analytical balance, in compliance with the standard ISO 8655-6

Requirements

The test water container is filled with test water.

Procedure

- ▶ Check whether the following conditions are met:
 - The required ambient conditions have been complied with (see Chapter “11.2 Ambient Conditions at the Installation Site”, page 35).
 - The device, tips and test water have been stored in the room for at least two hours so that they have adjusted to the ambient conditions.
 - The “Pipetting” pipetting mode is set in the device.
 - The aspirating speed and dispensing speed are set to 7.
- ▶ If necessary: Ensure that the conditions are complied with or adjust the settings on the device.

7.7.1 Aspirating the Test Water

The conditions for aspirating the test water must be complied with (see Chapter “11.6.1 Conditions for Aspirating the Test Liquid”, page 39).

Procedure

- ▶ Adjust the preferred test volume (V_S).
- ▶ Apply the tip to the tip cone.
- ▶ To achieve a humidity balance in the device: Aspirate and dispense the test water 5 times with the tip.
- ▶ Aspirate the test water. To do this, proceed as follows:
 - ▶ Hold the device vertically, press the operating button and immerse the tip below the surface of the water to the specified immersion depth.
 - ▶ Slowly release the operating button.
 - ▶ Comply with the specified wait time.
- ▶ Remove the device from the test water container vertically.

7.7.2 Dispensing Test Water and Performing the Measurement

We recommend performing 10 measurements. The tip must be replaced after 5 measurements.

Requirements

The analytical balance is ready for measuring.

Procedure

- ▶ Dispense the test water. To do this, proceed as follows:
 - ▶ Hold the tip above the liquid level at an angle of 30° - 40° on the inner wall of the measuring container.
 - ▶ Press and hold the operating button and release the test water into the measuring container.
 - ▶ In order to remove drops on the tip: Drag the tip 8 - 10 mm along the inner wall of the measuring container.
- ▶ Release the operating button.
- ▶ Remove the device from the measuring container vertically.
- ▶ Read off the weight in mg (m_i).
- ▶ Repeat the test cycle until 10 measurements have been recorded. Replace the tip after five test cycles.

7.7.3 Evaluating Measured Values

Requirements

Ten measurements have been recorded.

Procedure

- ▶ Convert the recorded masses (m_i) into volume (V_i) by multiplying with a correction factor Z. The following applies here: $V_i = m_i \cdot Z$ (for correction factor Z, see Chapter 11.6.2, page 39).
- ▶ Calculate the average volume: (V): $V = \sum(V_i)/10$.
- ▶ To evaluate conformity: Calculate the systematic error " e_s " of the measurement. Use the following formula to do this:
 - In μL : $e_s = V - V_s$
 - Or in %: $e_s = 100 (V - V_s)/V_s$
 - V_s = selected test volume
- ▶ For the conformity assessment, calculate the random measurement deviation as standard deviation or as variation coefficient:
 - As standard deviation (n = number of measurements (10))
 - As variation coefficient $C_v = 100\% \text{ sr} / V$

$$s = \sqrt{\frac{\sum(V_i - \bar{V})^2}{n - 1}}$$

- ▶ Compare the systematic error and the random error with the values of the performance specification from your own laboratory.
- ▷ If the measurement results are within the performance specification: The device is ready for use.
- ▷ If the measurement results are **not** within the performance specification:
 - ▶ Check the device for both systematic errors and random errors.
 - ▶ Ensure that a suitable tip is used.
 - ▶ Ensure that a good seal has been formed between tip and tip cone.
- ▷ If necessary: Adjust the device (see Chapter 7.8, page 30).

7.8 Adjusting the Pipette

The pipette is adjusted on delivery. A follow-up adjustment is required under the following conditions:

- When pipetting liquids which differ from water in density, viscosity, vapor pressure, or other quality.
- When reverse pipetting.
- When the geometry of the tip used clearly differs from standard tip geometry.
- When the pipette is used at high altitudes.
- The pipette routine test indicates a performance specification error of the pipette.

NOTICE

Risk of damage to the multi-channel pipette from improper handling!

The lower part of the pipette will move during adjustment. Allow it to move freely to prevent breaking the pipette.

- ▶ When adjusting multi-channel models, hold the pipette by the handle only.
-

Procedure

- ▶ Remove the cover of the calibration screw on the back of the housing using the adjustment tool.
- ▶ Insert the hexagonal head of the adjustment tool into the thread of the calibration nut.
- ▶ Turn the adjustment tool counterclockwise to reduce the volume or clockwise to increase the volume.
- ▶ Repeat checks of the pipette until the test results are correct (see Chapter "7.7 Performing the Routine Test", page 28).
- ▶ If the pipette has been adjusted for the use of liquids other than water, attach a label to the outside of the pipette with the name of the liquid and the adjusted volume range. To do this, the supplied stickers can be used for labeling.

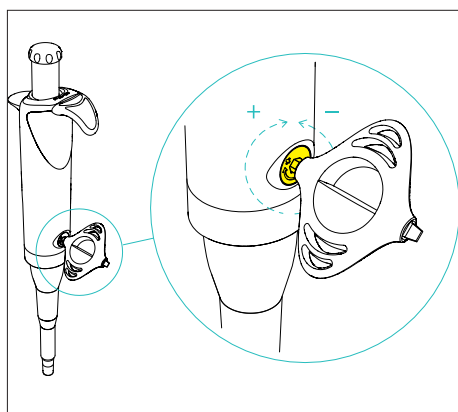

8 Malfunctions

Problem	Possible Cause	Solution
Droplets left in the tip	Unsuitable tip	Only use original Sartorius tips
Leakage / pipetted volume too small	Pre-rinsing the tip was not successful	Pre-rinse the tip again
	Tip incorrectly attached	Attach tip securely
	Unsuitable tip	Only use original Sartorius tips
	Foreign particles between the tip and the cone	Clean tip cone, attach new tip
	Tip cone holder incorrectly tightened	Tighten tip cone holder
	Pipette damaged	Send to Sartorius Service for servicing
Pipette outside established performance specifications	Incorrect operation	Follow instructions
	Unsuitable tip	Use original Sartorius tips
	Adjustment altered	Readjust the pipette
Operating button jammed or moves erratically	Liquid has penetrated the tip cone and dried	Clean and grease piston and seal Clean tip cone
	Safe-Cone Filter has been contaminated	Change filter
	Insufficient amount of grease on piston and seal	Grease as required
Tip ejector jams or moves erratically	Tip ejector collar has been contaminated	Remove and clean tip ejector collar and tip cone

9 Storage and Shipping

9.1 Storing

Procedure

- ▶ Clean the device.
- ▶ Store the device according to the ambient conditions (see Chapter “11.4 Cleaning Procedure and Cleaning Agent”, page 38).
- ▶ Store the device vertically, e.g., in a pipette stand.

9.2 Returning the Device and Parts

Defective devices or parts can be returned to Sartorius. Returned devices must be clean and properly packed.

Transport damage as well as measures for subsequent cleaning and disinfection of the device or parts by Sartorius are charged to the sender.

Devices contaminated with hazardous materials, e.g., harmful biological or chemical substances, will **not** be accepted for repair or disposal.

Procedure

- ▶ Ensure that the pipette has been decontaminated before you send it for repair or calibration (see Chapter “7.5 Sterilizing the Pipette”, page 26). Be sure to note any hazardous material that the pipette has been exposed to.
- ▶ Contact Sartorius Service for instructions on how to return devices or parts (see www.sartorius.com).
- ▶ Pack the device and its parts properly for return.

10 Disposal

10.1 Disposing of the Device and Parts

The device and the device accessories must be disposed of properly by disposal facilities.

Requirements

The device is decontaminated.

Procedure

- ▶ Dispose of the device in accordance with local government regulations.
- ▶ Dispose of the packaging in accordance with local government regulations.
- ▶ Dispose of the consumables in accordance with local government regulations.

11 Technical Data

11.1 Dimensions and Weights

11.1.1 Single-channel model

		725010	725020	725030	725050	728060	728070	728080	728090
	Unit	Value	Value	Value	Value	Value	Value	Value	Value
Dimensions (length)	mm	235	235	247	237	233	237	211	213
Weight	g	76	75	77	80	75	80	85	103

11.1.2 Multichannel model

		728120	728130	728140	728220	728230	728240
	Unit	Value	Value	Value	Value	Value	Value
Dimensions (length)	mm	243	245	241	243	245	241
Weight	g	135	140	135	160	170	160

11.2 Ambient Conditions at the Installation Site

	Unit	Value
Laboratory, for indoor use only		
Pollution level according to IEC 61010-1		II
Maximal height above sea level	m	2000
Suitable for protection class		
Protection class of the device, as per DIN EN 60529-1		IP 40
Temperature		
In operation	°C	+15 - +30
During performance review	°C	+15 - +30
In storage during transport	°C	-20 - +40
Relative humidity, in operation		
At temperatures up to 31°C, maximum	%	80
No potentially explosive areas		
Other properties		
Store dry		

11.3 Materials

11.3.1 Upper Part and Lower Part of Housing

Component	Materials												
	Polyetherimide (PEI)	Silicone (SI)	Stainless steel (SS)	Polypropylene (PP)	Polyamide (PA)	Polycarbonate (PC)	Polyethylene (PE)	Polyphenylene sulfide (PPS)	Polyvinylidene fluoride (PVDF)	Fluoroelastomer (FKM)	Ethylene propylene diene monomer (EPDM)	Other	
Top section of the housing													
Operating button	-	x	-	-	x	-	-	-	-	-	-	-	
Finger support	-	-	-	x	-	-	-	-	-	-	-	-	
Tip ejector button	-	-	-	-	x	-	-	-	-	-	-	-	
Handle	-	-	-	x	-	-	-	-	-	-	-	-	
Volume lock button	-	-	-	x	-	-	-	-	-	-	-	-	
Calibration screw cover	-	-	-	x	-	-	-	-	-	-	-	-	
Display	-	-	-	-	-	x	-	-	-	-	-	-	
Lower part of the housing													
Tip cone housing (multi-channel models)	-	-	-	-	x	-	-	-	-	-	-	-	
Safe-Cone Filter	-	-	-	-	-	-	x	-	-	-	-	-	
Tip ejector bar (multi-channel models)	-	-	-	-	x	-	-	-	-	-	-	-	
Tip ejector collar (single-channel models)	-	-	-	x	-	-	-	-	-	-	-	-	

11.3.2 Model-Dependant Materials of Lower Part of Housing (lower part) and Tip Ejector Components

Component	Materials										
	Polyetherimide (PEI)	Silicone (SI)	Stainless steel (SS)	Polypropylene (PP)	Polyamide (PA)	Polycarbonate (PC)	Polyethylene (PE)	Polyphenylenesulphide (PPS)	Polyvinylidene fluoride (PVDF)	Fluoroelastomer (FKM)	Ethylene propylene diene monomer (EPDM)
Locking ring											
Only for 10,000 µl model	x	-	-	-	-	-	-	-	-	-	-
All other models	-	-	-	-	x	-	-	-	-	-	-
Tip cone											
For 3 µl 10 µl 20 µl 100 µl models	-	-	-	-	-	-	-	-	x	-	-
For 200 µl models, single-channel	-	-	-	-	-	-	-	x	-	-	-
For 300 µl models	x	-	-	-	-	-	-	-	-	-	-
For 1,000 µl 5,000 µl 10,000 µl models	-	-	-	-	-	-	-	x	-	-	-
Piston											
For 3 µl 10 µl 20 µl models	-	-	x	-	-	-	-	-	-	-	-
For 100 µl single-channel model	-	-	-	-	-	-	-	x	-	-	-
For 100 µl multi-channel model	x	-	-	-	-	-	-	-	-	-	-
For 200 µl 300 µl models	x	-	-	-	-	-	-	-	-	-	-
For 1,000 µl 5,000 µl 10,000 µl models	-	-	-	-	-	-	-	x	-	-	-
Piston seal											
For 3 µl 10 µl 20 µl 10,000 µl models	-	-	-	-	-	-	-	-	-	x	-
For 100 µl 200 µl 300 µl 1,000 µl 5,000 µl models	-	-	-	-	-	-	-	-	-	-	x

11.4 Cleaning Procedure and Cleaning Agent

	Unit	Value
Approved cleaning procedures		
Wiping the device surfaces with a lightly moistened cloth		
Wiping the device surfaces dry		
Autoclaving		
UV radiation		
Autoclaving		
Autoclaving temperature, maximum	°C	121
Permissible overpressure	bar	1
Duration, maximum	min	20
Approved cleaning agents		
Ethanol (70%)		
Isopropyl alcohol (60%)		
Mild cleaning agent, suitable for the device materials		

11.5 Adjustment

11.5.1 Initial Adjustment

Type of adjustment by manufacturer in accordance with ISO 8655-1

On dispensing (Ex) of the selected volume (test volume), at 20 °C

11.6 Routine test

11.6.1 Conditions for Aspirating the Test Liquid

Test volume (µL)	Immersion depth of the pipette tip during aspiration (mm)	Wait time (s)
≤ 1	1 - 2	1
> 1 to 100	2 - 3	1
> 100 to 1 000	2 - 4	1
> 1 000 to 20 000	3 - 6	3

11.6.2 Correction Factor Z (µL /mg) for Routine Test

Temperature (°C)	Air Pressure (kPa)			
	95	100	101.3	105
20.0	1.0028	1.0028	1.0029	1.0029
20.5	1.0029	1.0029	1.0030	1.0030
21.0	1.0030	1.0031	1.0031	1.0031
21.5	1.0031	1.0032	1.0032	1.0032
22.0	1.0032	1.0033	1.0033	1.0033
22.5	1.0033	1.0034	1.0034	1.0034
23.0	1.0034	1.0035	1.0035	1.0036
23.5	1.0036	1.0036	1.0036	1.0037

The values in the table represent the most common values. For the full table, or for formula to calculate correction factor the standard ISO 8655-6 must be considered.

11.7 Performance Specifications

11.7.1 Single-Channel Models

Model	Color of the operating button	Volume range	Maximum permitted error limits as per ISO 8655					
			Test volume		Systematic errors*		Random errors*	
			Unit	Unit	Unit	Unit	Unit	Unit
			µL	µL	%	µL	%	µL
Value	Value	Value	Value	Value	Value			
725010	⑤	0.3–3	3	1.6	0.048	0.8	0.024	
			1.5	3.0	0.045	1.6	0.024	
			0.3	12.0	0.036	6.0	0.018	
725020	⑤	1–10	10	1.0	0.1	0.6	0.06	
			5	1.5	0.075	1.0	0.05	
			1	3.0	0.03	2.0	0.02	
725030	⑤	2–20	20	1.0	0.2	0.4	0.08	
			10	1.5	0.15	0.7	0.07	
			2	6.0	0.12	3.0	0.06	
725050	⑤	10–100	100	0.8	0.8	0.2	0.2	
			50	1.0	0.5	0.3	0.15	
			10	3.0	0.3	1.0	0.1	
725060	⑤	20–200	200	0.6	1.2	0.2	0.4	
			100	1.0	1	0.3	0.3	
			20	2.5	0.5	0.9	0.18	
725070	⑤	100–1000	1000	0.7	7	0.2	2	
			500	0.9	4.5	0.2	1	
			100	3.0	3	0.6	0.6	

* The values specified for the systematic and random error limits apply under the following conditions:

- When using the specified models with suitable non-sterile Sartorius Optifit tips
- When calculating the values under strictly controlled conditions during type examinations in accordance with ISO 8655

The values specified in ISO 8655 for the systematic and random error limits apply under the following conditions:

- When using the specified models with other Sartorius tips

Model	Color of the operating button	Volume range	Maximum permitted error limits as per ISO 8655					
			Test volume		Systematic errors*		Random errors*	
			Unit	Unit	Unit	Unit	Unit	Unit
			µL	µL	%	µL	%	µL
		Value	Value	Value	Value			
725080	⑤	500-5000	5000	0.6	30	0.2	10	
			2500	0.7	17.5	0.25	6.25	
			500	2.4	12	0.6	3	
725090	⑤	1000-10,000	10000	0.6	60	0.2	20	
			5000	1.2	60	0.3	15	
			1000	3.0	30	0.6	6	

* The values specified for the systematic and random error limits apply under the following conditions:

- When using the specified models with suitable non-sterile Sartorius Optifit tips
- When calculating the values under strictly controlled conditions during type examinations in accordance with ISO 8655

The values specified in ISO 8655 for the systematic and random error limits apply under the following conditions:

- When using the specified models with other Sartorius tips

11.7.2 Multichannel Models

Model	Number of channels	Color of the operating button	Volume range	Maximum permitted error limits as per ISO 8655					
				Test volume		Systematic errors*		Random errors*	
				Unit	Unit	Unit	Unit	Unit	Unit
				µL	µL	%	µL	%	µL
Value	Value	Value	Value	Value	Value				
725120 725220	8 12	⑤	1–10	10	5	1.5	0.15	1.0	0.1
				1		2.5	0.125	2.0	0.1
						5.5	0.055	4.0	0.04
725130 725230	8 12	⑤	10–100	100	50	0.9	0.9	0.4	0.4
				10		1.2	0.6	0.6	0.3
						4.0	0.4	2.0	0.2
725140 725240	8 12	⑤	30–300	300	150	0.6	1.8	0.25	0.75
				30		1.0	1.5	0.4	0.6
						3.0	0.9	1.0	0.3

* The values specified for the systematic and random error limits apply under the following conditions:

- When using the specified models with suitable non-sterile Sartorius Optifit tips
- When calculating the values under strictly controlled conditions during type examinations in accordance with ISO 8655

The values specified in ISO 8655 for the systematic and random error limits apply under the following conditions:

- When using the specified models with other Sartorius tips

11.8 Conformity

The device is developed and manufactured in accordance with the requirements of the following standards

ISO 9001

ISO 13485

12 Accessories and Consumables

12.1 Accessories

This table contains a selection of the accessories that can be ordered. For information on other products, contact Sartorius.

Item	Quantity	Order number
Pipette holder	1	LH-727640
Carousel stand for 6 pipettes	1	LH-725630
Linear pipette stand	1	725620

12.2 Consumables

This table contains a selection of the consumables that can be ordered. For information on other products, contact Sartorius.

Item	Quantity	Order number
Optifit Tips, 0.1-10 µL, single rack	1	790010
Optifit Tips, 0.1-10 µL, refill pack	1	790013
Optifit Tips, 0.1-10 µL, refill tower	1	790011
Safetyspace® Filter-Tip, 0.1-10 µL, single rack	1	790011F
Safetyspace® Filter-Tip, 0.5-200 µL, single rack	1	790101F
Safetyspace® Filter-Tip, 50-1,000 µL, single rack	1	791001F
Extended Standard Tip, 0.1-10 µL, single rack	1	783210
Extended Standard Tip, 10-1,000 µL, single rack	1	LH-X781000
Extended Filter Tips 0.1-10 µL, single rack	1	783201
Extended Filter Tips 10-1,000 µL, single rack	1	LH-XF781001
Safe-Cone Filter, standard, Ø6.73 mm	50	721005
Safe-Cone Filter, standard, Ø5.33 mm	50	721006
Safe-Cone Filter, standard, Ø3.15 mm	50	721007
Safe-Cone Filter, standard, Ø2.51 mm	50	721008
Safe-Cone Filter, standard, Ø1.83 mm	50	721014
Tweezers for filter replacement	1	721009

13 Sartorius Service

Sartorius Service is available for queries regarding the device. Visit the Sartorius website (www.sartorius.com) for information about the service addresses, services provided, or to contact a local representative.

For inquiries about the device or when contacting Sartorius Service in the event of a malfunction, ensure that you have the device information, e.g., serial number, close at hand so you can pass it on to Sartorius Service. To do this, refer to the information on the manufacturer's ID label.

Sartorius Liquid Handling oy
Tulppatie 1
00880 Helsinki, Finland

Lhinfo.finland@sartorius.com
www.sartorius.com

The information and figures contained in these instructions correspond to the version date specified below.

Sartorius reserves the right to make changes to the technology, features, specifications and design of the equipment without notice.

Masculine or feminine forms are used to facilitate legibility in these instructions and always simultaneously denote all genders.

Copyright notice:

These instructions, including all components, are protected by copyright.

Any use beyond the limits of the copyright law is not permitted without our approval.

This applies in particular to reprinting, translation and editing irrespective of the type of media used.

Last updated:

11 | 2025

© 2025

Sartorius Liquid Handling oy
Tulppatie 1
00880 Helsinki, Finland

SP | Publication No.: WML6001-e251104